

A Hidden Barrier Giving
Tangible Benefits



GK Standard Type



GK High-Power Type



MK High-Power Type

Mitsubishi Electric Air Curtains are the perfect way to provide your premises a quiet, efficient and powerful operation.

The benefits of Air Curtains

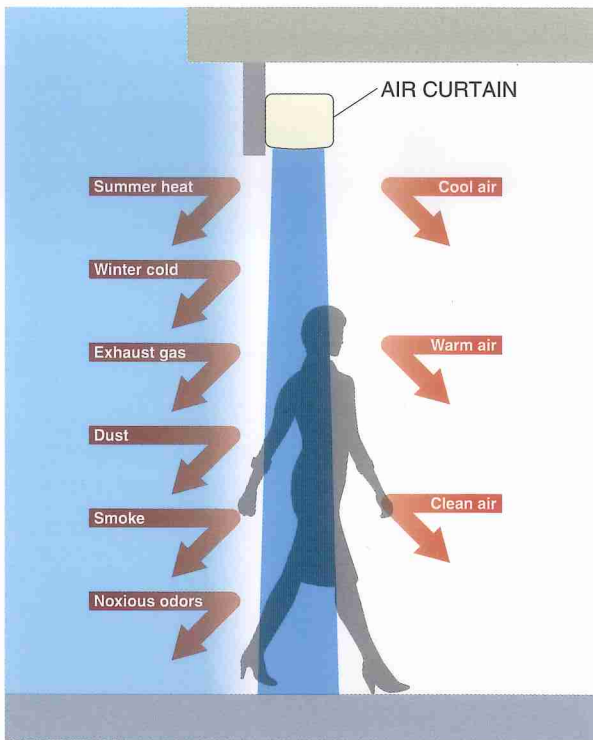

◆ Temperature Insulation Effectiveness

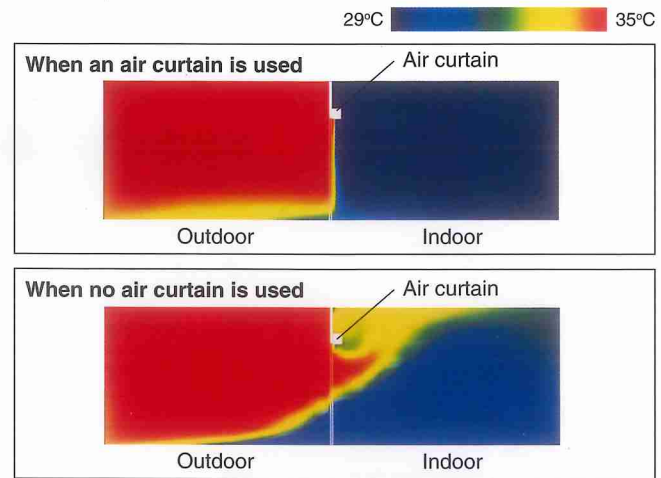

Experiments have proven that the air curtain effectively blocks 70-90% of outdoor heat or cold air, where a glass panel is assumed to block them 100%. (The effect may vary according to the difference between indoor and outdoor temperatures, whether there is wind outdoors, or the height of the air curtain.)

Air Velocity Distribution(m/s)

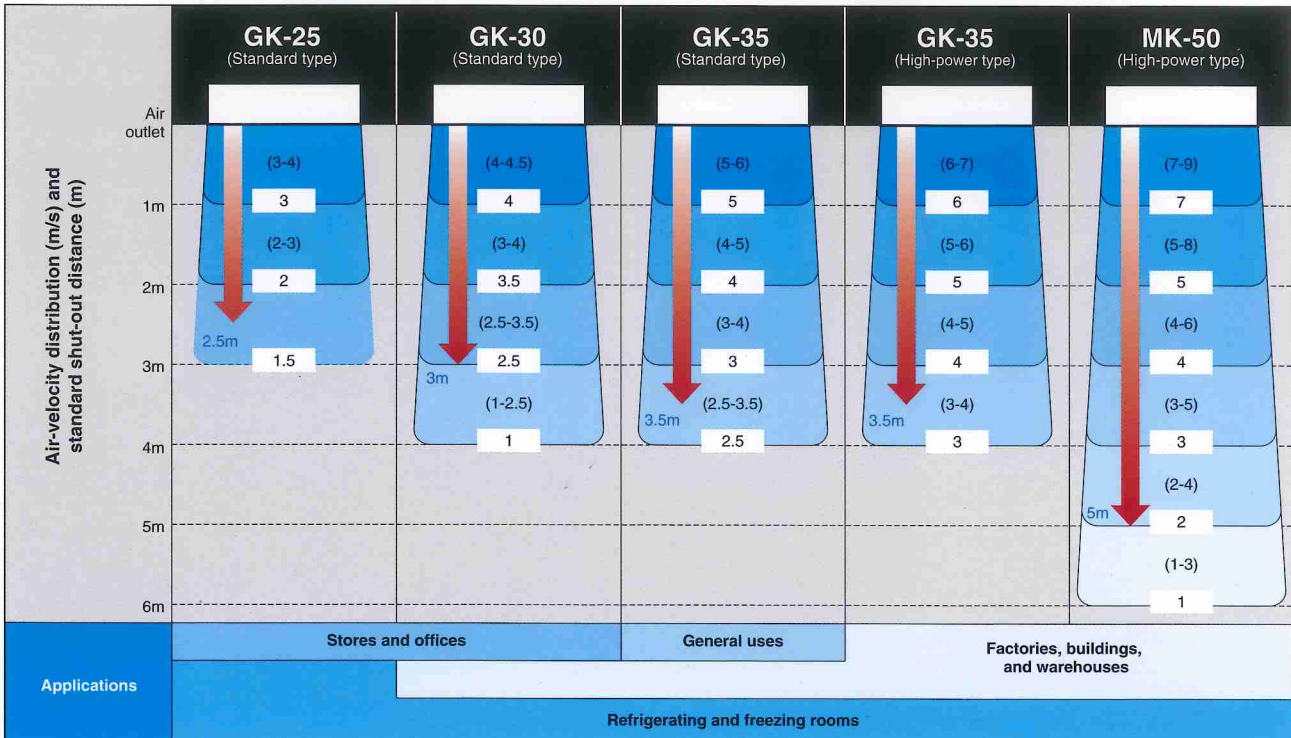

*The figure in □ indicates average velocity (m/s) at the given distance.

*The figure in parentheses indicates maximum velocity (m/s) in each one(1) meter square area.

*The above shows velocities in spaces free of any differences between outdoor and indoor pressure, temperature, or ambient wind.

with a comfortable, clean and hygienic environment while saving energy with

Air Curtain Range

GK Standard Type



*Operating conditions: Ambient and transfer air temperatures between -10°C and +45°C, and relative humidity of 90% or less at room temperature. Usage outside of this range may result in burning, deformation, irregular rotation, or damage.

Applicable for



Specifications

Model	Power Supply	Fan Speed	Airflow Rate [m ³ /h] (50/60Hz)	Current [A] (50/60Hz)	Power Consumption [W] (50/60Hz)	Max. Air Velocity [m/sec] (50/60Hz)	Noise [dB] (50/60Hz)	Weight [kg]
GK-2509YS2-CE	Single-phase, 50/60Hz, 220-240/220V	High	1260-1340/1220	0.25-0.26/0.31	54-61/69	9.5/9.5	44.5-46/44	10.5
		Low	910-1100/820	0.22-0.24/0.24	48-57/53	7/7	38-41/35	
GK-2512AS2-CE		High	1550-1620/1560	0.30-0.32/0.40	67-77/89	9.5/9.5	45-46/46	13.3
		Low	1160-1370/1000	0.25-0.28/0.29	55-66/64	7/7	37.5-42/36	
GK-3009AS2-CE		High	1450-1470/1640	0.41-0.49/0.47	80-96/102	12/12	47-47.5/50	11
		Low	1200-1250/1060	0.34-0.35/0.36	71-80/77	8/8	43.5-45.5/40	
GK-3012AS2-CE	High	1740-1760/1950	0.45-0.53/0.60	96-114/125	12/12	47.5-48.5/51	14	
	Low	1460-1600/1220	0.38-0.40/0.43	84-96/95	8/8	46-47/42		
GK-3509CS-E2	Single-phase, 50Hz, 220-240V	High	2100	0.87-0.94	191-223	13.5	58-58	22
Low		1860	0.74-0.75	155-170	11	55.5-56		
GK-3512DS-E2		High	2640	1.05-1.13	227-267	13.5	58-58.5	
Low	2310	0.89-0.90	187-206	11	55.5-56.5			

The printed color of the products is slightly different from those of the actual products. GK3509/3512 does not have a switch.

Dimensions

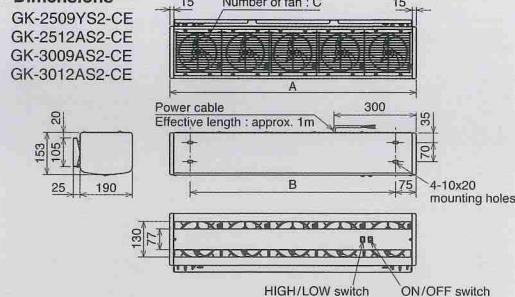

*The appearance may differ slightly depending on the model. Unit : mm

Dimensions

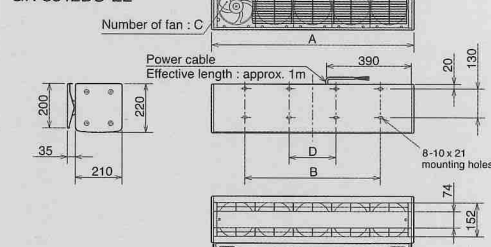

*The appearance may differ slightly depending on the model. Unit : mm

GK High-Power Type



*Operating conditions: Ambient and transfer air temperatures between -10°C and +45°C, and relative humidity of 90% or less at room temperature. Usage outside of this range may result in burning, deformation, irregular rotation, or damage.

Applicable for



Specifications

Model	Power Supply	Fan Speed	Airflow Rate [m ³ /h] (50Hz)	Current [A] (50Hz)	Power Consumption [W] (50Hz)	Max. Air Velocity [m/sec] (50Hz)	Noise [dB] (50Hz)	Weight [kg]
GK-3506SA	Single-phase, 50Hz, 220-240V	High	1440-1560	0.75-0.75	165-175	16-17.5	64.5-66.5	15.5
		Low	1190-1350	0.75-0.75	165-180	12-14	61-64	
GK-3509SA		High	2160-2340	1.1-1.1	250-265	16-17.5	66-68.5	20
		Low	1790-2030	1.1-1.1	250-270	12-14	63-66	
GK-3512SA		High	2880-3120	1.5-1.5	335-355	16-17.5	67.5-70	25
		Low	2380-2700	1.5-1.5	335-360	12-14	64.5-67.5	

The printed color of the products is slightly different from those of the actual products.

Dimensions

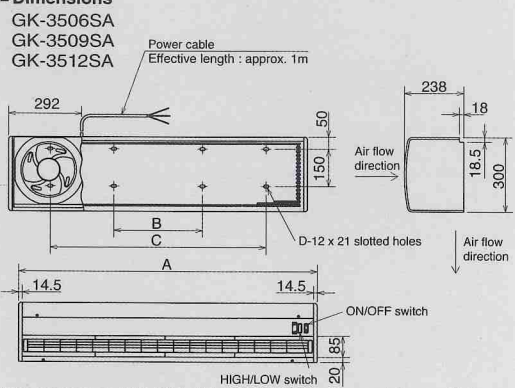

*The appearance may differ slightly depending on the model. Unit : mm

MK High-Power Type



*Operating conditions: Ambient and transfer air temperatures between -10°C and +45°C, and relative humidity of 90% or less at room temperature. Usage outside of this range may result in burning, deformation, irregular rotation, or damage.

Applicable for

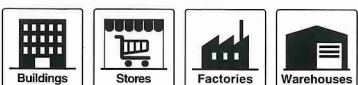

Specifications

Model	Power Supply	Fan Speed	Airflow Rate [m ³ /h] (50/60Hz)	Current [A] (50/60Hz)	Power Consumption [W] (50/60Hz)	Max. Air Velocity [m/sec] (50/60Hz)	Noise [dB] (50/60Hz)	Weight [kg]	
MK-5010T-E1	Three-phase, 50/60Hz, 380-415/380V	50	3950	0.64-0.67	336-368	16	62	25.5	
		60	4250	0.74	432	17	64		
MK-5012T-E1		50	5000	0.80-0.84	420-460	16	63.5		32
		60	5400	0.93	540	17	63.5		

The printed color of the products is slightly different from those of the actual products. The above specifications are subject to change without notice due to continuing product improvement.

Dimensions

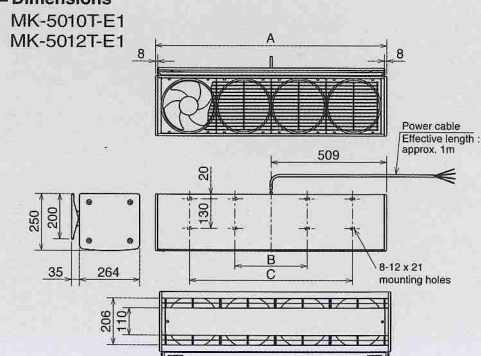

*The appearance may differ slightly depending on the model. Unit : mm

Keys to The Effective Use of the Air Curtains

1 Install the air curtain where the impact of outdoor (lateral) wind is insignificant.

2 To prevent the flow of air from affecting people inside the room, install the air curtain as far as possible from the nearest people. If it is installed in proximity to the nearest people, a windbreak would be effective.

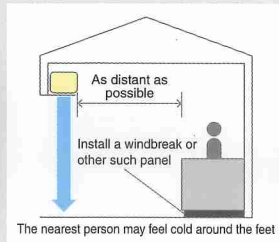

3 In an air-conditioned room, install the air curtain sufficiently away from the air conditioner.

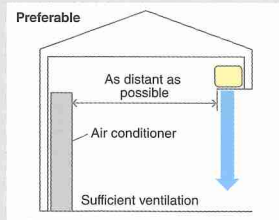

4 Install an air curtain that is the same width as the doorway or slightly wider.

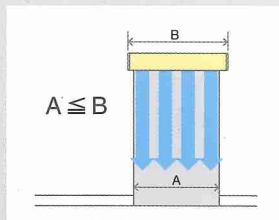

5 Install the air curtain flat against the mounting surface. Any unnecessary space should be boarded up with a decorative panel or board.

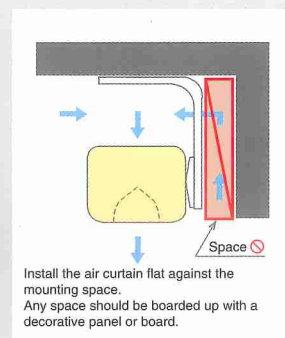

6 Install an air curtain in all doorways and openings.

7 For effective operation of the air curtain, install air vents (or air supply) to avoid the accumulation of negative pressure inside the room.

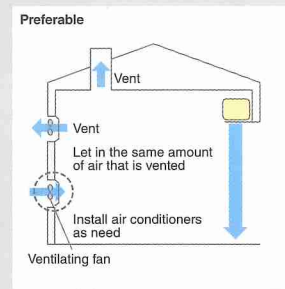

8 For effective operation of the air curtain, the length between the air curtain and the other side of the wall has to be wider than openings.

The direction of air can be adjusted according to your needs. Take into account the following when adjusting the direction of the generated wind.

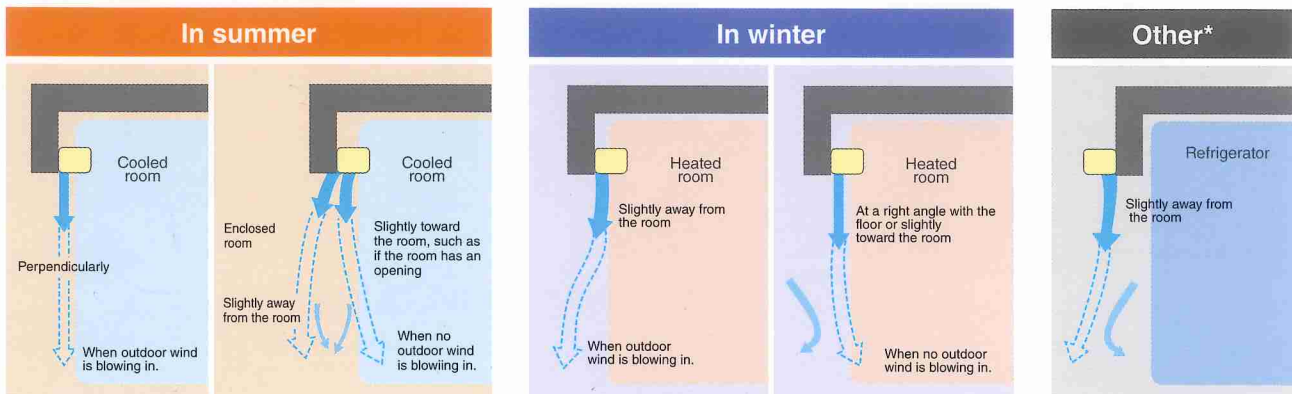

*The inside temperature differs significantly from the outside temperature (such as in the case of a refrigerator.)
(Make sure there is nothing in the way of the generated wind.)

MITSUBISHI ELECTRIC CORPORATION

HEAD OFFICE : TOKYO BLDG., 2-7-3 MARUNOUCHI, CHIYODA-KU, TOKYO 100-8310, JAPAN
www.MitsubishiElectric.com